

POWER SYSTEM DYNAMICS VISUALIZATION FOR EARLY-STAGE ENGINEERING STUDENTS AND NON-TECHNICAL AUDIENCE

Federico Milano

University College Dublin (IRELAND)

Abstract

This paper proposes a simple mechanical analogy to visualize the dynamic response of electrical energy systems that is easy to understand for early-stage undergraduate engineering students and a non-technical audience. The paper presents a novel visualization approach of power system dynamics that resembles the most important dynamic response and controls of a power system. This includes the generation/load balance, synchronous machine response, and primary and secondary frequency control. The impact of renewable sources on the dynamic response of the system is also illustrated.

Keywords: power system dynamics, power system visualization, early-stage engineering students, non-technical audience.

1 INTRODUCTION

In the experience of the author, who has been teaching power system modelling, control and stability analysis for about 15 years, to understand the dynamic response of power systems is challenging at any stage of engineering studies [1-8]. Power systems dynamics, in fact, are ruled by non-linear equations and hundreds of different devices. Even experienced researchers often face difficulties to understand all details of a time domain simulation. As is can be easily expected, to understand such dynamics is even more challenging for non-technical audience and early-stage engineering students, i.e., people who do not have any previous knowledge of automatic control and system dynamics.

The author has recently been involved in a H2020 project, RESERVE, that is aimed at defining a novel frequency and voltage controls for networks with high penetration of renewable energy resources and non-synchronous generation. One of the activities of the project is the dissemination of results and the presentation to a non-technical audience of the problems to be solved and the solution found. This has made necessary to show in an as visual and direct way as possible the dynamic behaviour of an electrical energy system. This has to be done assuming that the audience not only does not have a strong base on electrical machines or nonlinear system dynamics but might not be an engineer at all. This leads to the need to avoid, whenever possible, equations, technical language and conventional plots.

In the same period, the author has become the coordinator of the module Electrical Energy Systems, which is a second-year module for mechanical, electrical and electronic engineering students at University College Dublin, Ireland. This is a challenging module for a variety of reasons. The module is offered at a stage at which students have seen only very basic concepts of electric and electronic circuit theory. These students have little knowledge of dynamical systems and no knowledge of control theory, electrical machines and power system operation. Thus, they are, to some extent, comparable to a non-technical audience.

The very first difficulty that everybody faces when being introduced for the first time to the dynamic behaviour of power systems is the fact that the system *per se* cannot be visualized. One can easily write the equations, but there is no mental representation of the interaction of the machines. Even after simulating the transient behaviour of the system with a dedicated software, it appears difficult to handle the results as there are too many variables to look at. Only very few of these are actually relevant but it might take a while before one is able to understand in which way the devices interact and which are the most meaningful parameters and their impact on the system. For this reason, in Electrical Engineering programmes often include an entire module that covers the dynamic behaviour and the control of power systems.

The proposed approach, while necessarily approximated, is based on a simple mechanical analogy. The power system is represented as a mechanical scale with generation on one side of the beam and load on the other. Synchronous machine inertia and frequency controllers are represented as springs

and dampers connected to the arms of the scale. Since the underlying core behaviour of a power system resembles a set of second order differential equations, i.e., shows damped oscillations after the occurrence of a disturbance, the analogy is good enough to introduce basic dynamic and control concepts.

The paper provides the following contributions.

- A simplified mechanical analogy to visualize most important electric power system dynamics.
- A thorough discussion on the physical appropriateness as well as of the limitations of the proposed analogy.
- A discussion on the didactic value of the proposed analogy based on the feedback of the students of the module Electrical Energy Systems offered by the author at University College Dublin, Ireland.
- A discussion on the main difficulties encountered by non-technical audience to grasp the main concepts of electrical energy system dynamics.

The remainder of the paper is organized as follows. Section outlines the key aspects of the model of a conventional power system whose dynamics are driven by synchronous generators and their controllers. The effect of renewable generation is also discussed in this section. Section 3 presents the proposed a simple mechanical and illustrates how it can emulate at the least the very basic principles that define the various dynamics and controls introduced in the previous section. Section 4 discusses the challenges encountered by the author while teaching to early-stage engineering students and introducing power system dynamics to the partners of the RESERVE project. Finally, Section 5 draws conclusions and outlines future work.

2 OUTLINES OF POWER SYSTEM DYNAMICS AND CONTROL

Conventional high-voltage power systems are composed of generation, transmission and distribution [9]. The generation, at least until recently, is based on synchronous machines and their primary and secondary regulators. The transmission system is composed of overhead lines, underground cables and transformers. These are dynamic components, but since their transients are very fast compared to those of synchronous machines, are generally modelled as steady-state lumped equations when studying the stability of the overall system. Finally, the distribution is modelled as a power consumption. In other words, medium and low voltage networks are represented using an aggregated model which is generally represented as a voltage-dependent active and reactive power consumption. Typically, no short-term dynamic is considered when modelling loads. It descends, thus, that the main dynamic devices of conventional systems are the synchronous machine and its controllers. In recent years, things got more complicated due to the penetration of renewable and/or distribute energy resources. These have dynamics that interact with those of the synchronous machines, and their response to the disturbances is completely different (and, at this time, not fully defined) as mostly based on power electronic converters whose control strategies can be implemented in many different ways. In addition to that, most renewable sources are also *stochastic*, e.g., wind and solar power plants. This implies that their power output is uncertain and volatile.

The remainder of this section presents the main concepts of the dynamic behaviour of synchronous machines, primary and secondary frequency controllers and the effect of renewable energy resources on the system dynamic. Typical time scales of synchronous machine electromechanical dynamics and active power regulations are shown in Figure 1.

2.1 Synchronous Machine Dynamics

The dynamics of a synchronous machine involve mechanical, electrical and magnetic variables. The detailed dynamic model of this machine is the object of late stage modules in electrical energy systems. Often this module is an option and, hence, not even all electrical engineering students do actually receive an introduction to the dynamic of this machine (see [7] and [8] for a discussion on this point).

The main dynamic, however is the mechanical one. At the very core, this dynamic can be formulated with the following equations:

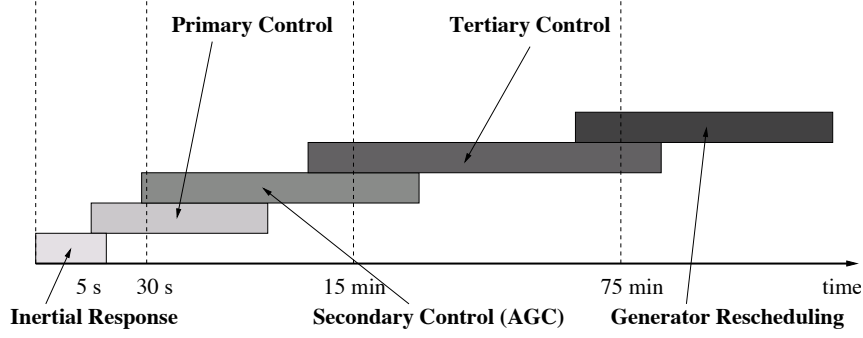

Figure 1. Typical time scales of synchronous machines and active power regulation.

$$\dot{\delta} = \omega \quad (1)$$

$$M\dot{\omega} = p_m - p_e(\delta) - D\omega \quad (2)$$

where δ is the rotor angle position, ω is the rotor speed deviation, e is the internal emf, v is the voltage at the terminal bus of the machine, x'_d is the transient reactance, M is the inertia constant, D is the damping, p_m is the mechanical generated power, and p_e is the electrical power injected into the grid and accounts for load consumption and transmission system losses. p_e is a nonlinear function of the rotor angular position of the machine. In particular, $p_e = K \sin \delta$ and, hence, for small variations, one can assume $p_e \approx K\delta$. In this paper, the variations of the voltage and internal emfs are neglected, for simplicity and because they do not substantially modify the dynamic response of the mechanical part of the machine.

The set of equations (1)-(3) are structurally the same as those of a mechanical pendulum and, as a matter of fact, synchronous machines oscillate around the equilibrium point. The main difference with a pendulum is that the steady-state condition of the synchronous machine is to rotate at the synchronous angular speed, whereas the pendulum is in steady-state when it does not move. Recalling the definitions of phasors and rotating reference frame [10], the similarity between synchronous machines and pendulum clocks matches fairly well. This point is the key for the visual approach that is thoroughly discussed in Section 3.

According to (1)-(3), the only condition for which the machines are in steady-state is when they are synchronous (see [10] for more details), i.e., their angular is the same. As a consequence, also the frequency of the system is constant and the same everywhere. It is relevant to note that, in per unit and in steady state, the rotor angular speed of the synchronous machines and the fundamental frequency of the system, e.g., 50 Hz in Europe, is the same quantity. As soon as a power unbalance occurs, i.e., $p_m \neq p_e$, the rotor speeds and rotor angles of the machines start to move. In a multimachine system, each machine will have, at least in the first few seconds after the disturbance and depending on the severity of the disturbance itself, its own speed, different from any other machine (see Figure 1). If the damping D is not null, the oscillations will slowly decrease until the system is again in steady-state. Note that, however, to attain the maximum efficiency of the overall system, the damping of synchronous machines has to be small.

After a while (unless the system collapses!) and due to damping, all machines synchronize. Probably the best way to communicate the fact that power systems are “synchronous” is to use the analogy with the synchronization of pendulum clocks as discovered by Huygens in 1665. Reference [8] duly discusses this analogy and proposes the classical metronome example as a technique to explain synchronization to early stage electrical and non-electrical engineering students. While the analogy between interconnected synchronous machines and metronomes is not a perfect match, the visual impact of a video showing such synchronization process always astonishes the students. An example of such a video is available at [11].

This paper does not discuss the synchronization effect. This is an important aspect of the synchronous machines but it is not crucial for non-technical audience. The assumption is that the machines are actually always synchronous and that (1)-(3) describes an equivalent aggregated model of all machines connected to the system. With this simplification, it is possible to show the effect of primary and secondary frequency controls. One should always remember, though, that, at least locally and in

the very early stage after any contingency, the speed of each machine is actually slightly different from those of all others and that there are as many oscillations modes as machines.

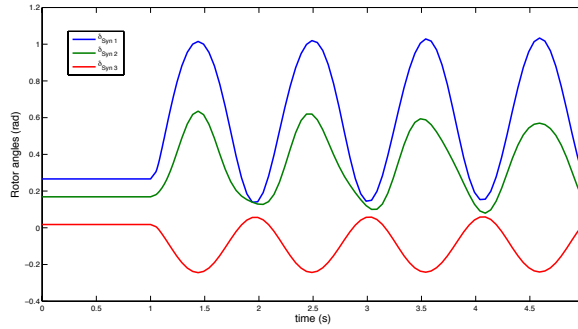

Figure 1. Typical dynamic response of uncontrolled synchronous machines after a contingency.

2.2 Primary Frequency Control

The function of the primary frequency control is to measure the rotor speed of the machine and vary adequately the mechanical torque of the turbine to reduce the error of the speed. The time scale of the dynamics of the primary frequency control is from few seconds to few tens of seconds, as indicated in Figure 1. A typical scheme of primary frequency control, including turbine governor, valve control and turbine dynamics is depicted in Figure 2. In the figure, the machine is represented through its inertia.

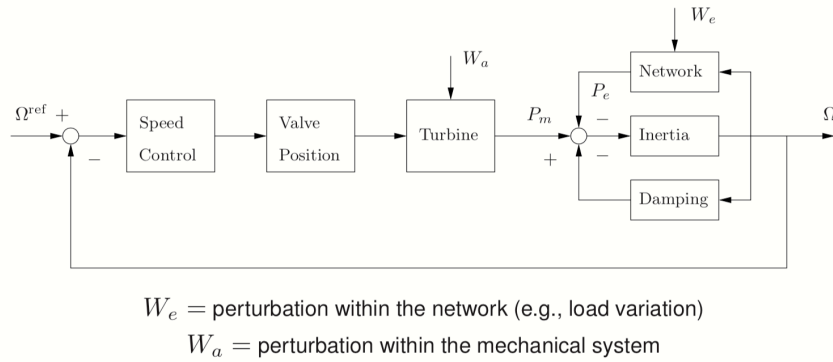

Figure 2. Typical scheme of a primary frequency controller.

For the purposes of this paper, the whole primary frequency control can be simplified with the following dynamic equation:

$$\dot{p}_m = -\frac{1}{R}\omega - p_m \quad (3)$$

where R is the *droop* coefficient. In steady-state, or assuming that the rate of change of the mechanical power is small, one has that the variation of the mechanical power is proportional to the inverse of the droop and the speed deviation. Equation (2) can thus be roughly approximated as:

$$M\dot{\omega} = p_e(\delta) - \left(\frac{1}{R} + D\right)\omega \approx K\delta - \frac{1}{R}\omega \quad (4)$$

The value of the droop is key for the dynamic response of the system and is responsible of the fact that, after a contingency, the steady state error of the frequency is not null, as illustrated in Figure 3.

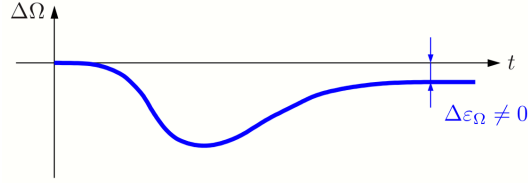

Figure 3. Typical time response of the primary frequency control after a contingency. Note that the frequency does not recover the initial value in steady-state.

2.3 Secondary Frequency Control

The secondary frequency control, often called automatic generation control (AGC), is a regional controller, managed by the system operator, and coordinates several generators to reschedule their active power set points in order to recover the synchronous reference frequency of the system. The AGC measure the frequency at a relevant bus of the system (pilot bus) and send a signal to each generator participating to the secondary frequency control, as shown in Figure 4. While there are several possible implementations of the block “Reg II” in Figure 4, for the purpose of this paper, we simply assume that the whole regulator is slow enough to be represented just as a variation of mechanical power, say Δp_m , in the equation of the primary frequency controller of the machines, as follows:

$$\dot{p}_m = -\frac{1}{R}\omega - p_m + \Delta p_m \quad (5)$$

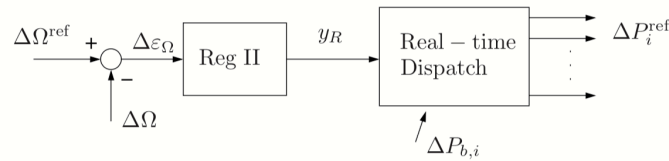

Figure 4. Typical scheme of principle of the secondary frequency control or AGC.

Figure 5 shows the typical dynamic response of the frequency following the primary and secondary frequency control of synchronous generators.

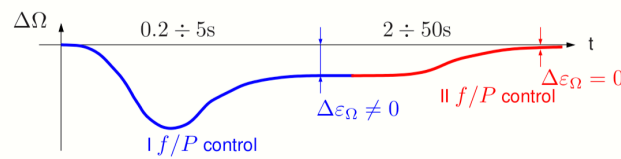

Figure 5. Typical dynamic response of the primary and secondary frequency control after a contingency. Note that the secondary frequency control is able to recover the reference frequency in steady-state.

2.4 Effect of Renewable Generation

As discussed above, renewable generation such as wind turbines and solar PV introduces a certain degree of randomness in the system. This can be split into two components: *uncertainty*, which is the deviation with respect to the power production forecast over a period of ten of minutes to few hours; and *volatility*, which is the noise on top of the average value of the active power production over the same period. In addition to that, renewable generation tends to be *non-synchronous*, meaning that its dynamic behaviour differs from that of a synchronous machine. While the dynamic response of such energy resources can be very diverse, the main feature that is common to all of them is that they do not provide *inertia* to the system. In summary, a system with high penetration of renewable generation can be described by a modified version of equation (2):

$$M\dot{\omega} = p_m + p_{ns}(t) - p_e - D\omega \quad (6)$$

where $p_{ns}(t)$ is the stochastic power generated by non-synchronous devices.

2.5 Overall simplified electromechanical model

Merging together equations (1)-(6) and assuming all the approximations discussed so far, we obtain the following expression that describes the dynamic response of synchronous machines and primary and secondary frequency controls:

$$M\ddot{\delta} + \frac{1}{R}\dot{\delta} - K\delta - \Delta p_m - p_{ns}(t) = 0 \quad (7)$$

which is a second order linear ordinary differential equation with, possibly, a time variant source due to renewable generation. Equation (8) will be assumed in the remainder of this paper.

3 PROPOSED MECHANICAL ANALOGY

Every basic module on physics and mechanics discusses the spring-mass-damper model. This is indeed a very common example to illustrate Newton's second law of motion and lead to the well-known second order differential equation linking position, velocity and acceleration and external forces. The so-called *impedance analogy* shows that the basic electric elements, namely, capacitances, inductances, resistances and generators, leads to the very same differential equation, at least formally, to the motion equations of the mass-spring-damper mechanical system (a detailed discussion on this analogy is given in [8]). In this section we proceed the other way around. We utilize a mass-spring-damper mechanical system to "visualize" the approximated model of the power system as discussed in the previous section and formally written as equation (7).

3.1 Steady-state Analogy

The conventional representation of the power balance by means of a beam scale is shown in Figure 6. The weights (or masses) at the two ends of the beam represent generator and load powers. When the system is balanced, the needle of the scale indicates 50 Hz, meaning that the generated power is equal to the consumed one:

$$p_m = p_e \quad (8)$$

where p_e accounts for load power consumption and transmission system losses as insidcated in the discussion of equation (2).

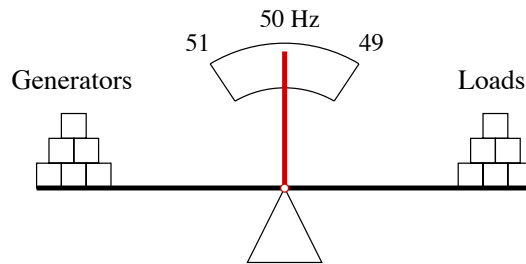

Figure 6. Conventional steady-state mechanical analogy.

The equivalence above has a subtle issue: the way it is drawn, any position of the beam is actually an equilibrium point if equation (8) is satisfied. On the other hand, the beam would tilt until it reaches some physical impediments if the two masses are not equal. Actual real-life beam scales, in fact, have their centre of mass below the rotation point. This trick makes the horizontal position a stable equilibrium point and for small mass imbalances, the deviation from the horizontal position is proportional to the imbalance. How to change the centre of mass of the scale and what this means in terms of the power system control is duly discussed in Section 3.3.

3.2 Inertia and Electromechanical Oscillations

Let us assume for now that the system includes synchronous machines but no control. The inertia of the machines has the effect of creating an undamped oscillator, which can be easily obtained through springs connected to one side of the beam (see Figure 7). The more the springs connected in parallel, the more the inertia of the systems. If we assume that the resting position of the springs is the horizontal, the equation that represents this situation is obtained from (7) by removing the effect of the primary and secondary control:

$$M\ddot{\delta} - K\delta = 0 \tag{9}$$

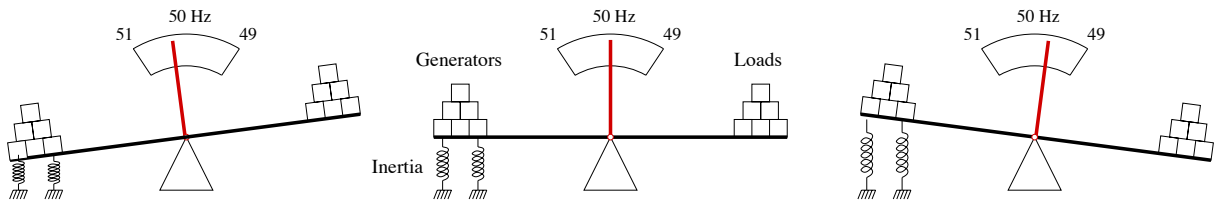

Figure 7. Mechanical springs represent the synchronous machine inertia.

This system will thus oscillate forever after a disturbance, i.e., if the beam is hit with a gentle push (but the masses are still balanced). These oscillations are undamped even if the transmission system include losses (which are accounted for in the term $K\delta$). To damp the oscillations one need either a damping factor D in the machine equations or a proper controller, which is discussed in the following section. In case we change one of the two masses, the system will still oscillate, but the average position of the beam will not be the horizontal anymore (e.g., the resting position of the springs). In other words, the amount of weight that is removed from the system has to be compensated by the elastic energy of the springs, either positive if the generator “weights” more than the load or negative if the loads “weights” more than the generators. This situation corresponds, in the actual power system, to the kinetic energy that is stored or released by the rotors of the machines.

3.3 Primary Frequency Control

To represent the primary frequency control, we connect a mass to the fulcrum of the beam to lower the center of mass of the scale. Moreover, we add mechanical dampers. The resulting mechanical system is shown in Figure 8. Whenever an unbalanced condition occurs, the scale will start to oscillate but the effect of the damper will prevent a sustained oscillation around the equilibrium point. Then the new equilibrium is given by the sum of the momenta of the three masses, generators, loads and primary frequency control. Note that the mass of the primary frequency control also represents a variation of a generated power. In practice, this power is the so-called “spinning reserve” of the turbines connected to the rotors of the synchronous machines.

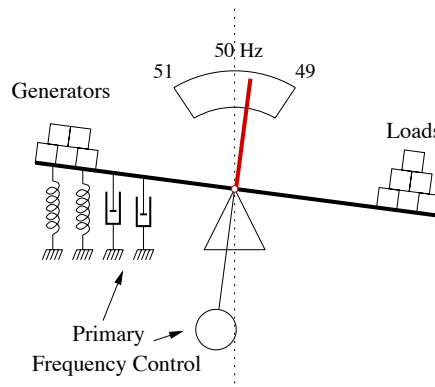

Figure 8. A low-mass center with damper represents the effect of primary frequency control.

It is also important to note that, if there is a power unbalance, the new equilibrium point cannot be the horizontal. This is consistent with the droop control of the synchronous machine discussed in Section 2.2.

3.4 Secondary Frequency Control

The secondary frequency control, or AGC, is represented in Figure 9. This is basically just a rescheduling of the active power set point of the turbines of the synchronous machines. The AGC is much slower than the primary frequency control (see Figure 1) and in the mechanical model its effect is mainly visible at the equilibrium. The representation in the figure is simplistic, however. In practice all generators will increase their power production to compensate a generator outage or a load increase.

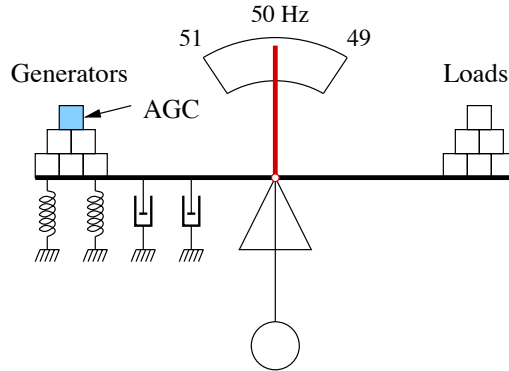

Figure 8. The AGC simply reschedules the active power set point of the machines.

3.5 Effect of Renewable Generation

Finally, we discuss the effect of renewable generation in the proposed equivalent mechanical model. This is basically an external, time-dependent “force”, which acts on the generator beam side. Moreover, it also decreases the total inertia, and hence the number of parallel springs, as well as the spinning reserve of the system. The result is shown in Figure 9 where the force $f(t)$ represents the active power of the renewable sources $p_{ns}(t)$ in (7). It has to be expected then that the system is overall less “stable” and its dynamic oscillations lead to bigger frequency variations and are less damped. These issues require a careful rethinking of the dynamic behavior and control opportunities of low-inertia systems as given in [13].

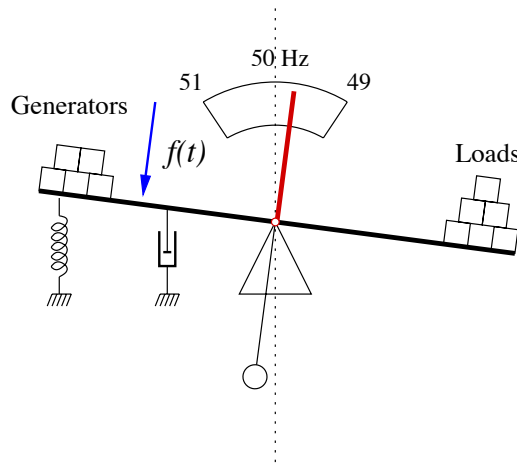

Figure 9. Renewable sources have several effects on the system: they add randomness and reduce inertia, spinning reserve and damping.

4 DIDACTIC CHALLENGES

This section briefly summarizes the most relevant issues encountered by the author when explaining basic power system dynamics to an audience with little or no technical background.

4.1 Challenges to Teach to Early-Stage Engineering Students

This topic is thoroughly covered in references [7] and [8]. This section briefly recalls the two most relevant challenges in the context of this paper.

- *Weak knowledge of differential equations.* While every student of any engineering programme has to attend a module on calculus and differential equations, these are typically taught by professors in mathematics, which do not provide “real-life” examples. The true understanding of differential equations as a mean to model reality comes much later in the engineering programme (third or even fourth stage).
- *Lack of previous knowledge.* The scientific language and notation used by electrical engineers is clearly different than that utilized in common practice. The lecturer cannot thus rely on previous knowledge or common sense as it happens for most basic topics of mechanical engineering. Moreover, the concepts of inertia, electric power and frequency control cannot be easily visualized.

The didactic challenges described above clearly require an *ad hoc* didactic strategy. In the experience of the author, the implementation of the “visual” approach discussed in the previous section and based on a relatively easy to understand mechanical analogy results useful to the students. The tradeoff of this approach is to communicate the main messages without “trivializing” too much the concepts discussed in class. It is thus very important to pay particular attention to stress the hypothesis and the several approximations that are assumed to get to equation (7).

4.2 Challenges to Teach to a Non-technical Audience

In the last two years, the author has been involved in the H2020 European Project RESERVE, which consists in the collaboration of two technical areas, telecommunications and power systems, to study the integration of renewable energy sources in power systems through “smart” solutions based on ICT. One of the main difficulties encountered at the beginning of the project was the communication between people belonging to different technical areas. For this reason, several tutorials have been put in place to explain ICT to power system partners and power systems to ICT ones. As expected, one of the most challenging issues was to explain the various time scales, dynamics and controllers that exist in conventional power systems. The author was involved in the preparation of some “didactic” material to be used not only within the project, but also for outreach and dissemination purposes. It is interesting to note that despite ICT and power system people basically utilize the same Maxwell laws, it was finally simpler to utilize a mechanical analogy rather than a technical explanation based on circuit and control theory to communicate basic power system concepts. We believe that this is mainly due to the fact that power systems are fundamentally dealing with “energy”, and thus are conceptually closer to the classical mechanical engineering, while ICT is dealing with “information”. Despite recent development of quantum physics suggest that information *is* energy, there still exists a wide gap, at least in our common perception and way of thinking, between these two concepts.

5 CONCLUSIONS

The paper presents a simple yet not trivial mechanical analogy that help illustrating the basic concepts of dynamic behavior and active power control of electric energy systems. The paper first shows that, in its very essence, the overall dynamic behavior of a power system can be described by a second order linear dynamic equation. This is, in turn, representable as a mass-spring-damper mechanical system. The trick utilized in the proposed analogy is to choose a beam scale to represent such a second order dynamical system, which allows “visualizing” the actual swing of synchronous machines as well as the effect of primary and secondary controllers and renewable generation. The feedback of both second stage engineering students and non-electrical engineering audience has been positive. Future work will focus on the visualization of “reactive power” a concept very specific of AC electric circuits that, so far, has not been possible to explain with any simple convincing analogy.

ACKNOWLEDGMENTS

This work is partly funded by the European Commission, under the H2020 funding scheme, RESERVE Consortium, Grant No. 727481 and by Science Foundation Ireland, under the Investigator Programme, Grant No. SFI/15/IA/3074.

REFERENCES

- [1] F. Milano, *Thinking Nonlinearly: Experience in Teaching Power System Stability Analysis in Engineering Programmes*, EDULEARN 2016, Barcelona, Spain, 4-6 July 2016.
- [2] F. Milano, *Problem Solving through Limit-case Analysis: Experience in Electrical Engineering Programmes*, EDULEARN 2016, Barcelona, Spain, 4-6 July 2016.
- [3] F. Milano, *A Systematic Method for Failure Diagnosis in Electrical Machine Lab Activities*, ICERI 2011, Madrid, Spain, 14-16 November 2011.
- [4] L. Vanfretti, and F. Milano, *Application of the PSAT, an Open Source Software, for Educational and Research Purposes*, IEEE PES General Meeting, Tampa, USA, 24-28 June 2007.
- [5] F. Milano, L. Vanfretti, J. C. Morataya, *An Open Source Power System Virtual Laboratory: The PSAT Case and Experience*, IEEE Transactions on Education, Vol. 51, No. 1, pp. 17-23, February 2008.
- [6] F. Milano, *Experience of Unix Terminal-based Labs for Undergraduate Modules on Power System Analysis*, EDULEARN14, Barcelona, Spain, 7-9 July 2014.
- [7] F. Milano, *Experience Teaching Electrical Energy Systems to Non-electrical Engineering Students*, EDULEARN 2017, Barcelona, Spain, 3-5 July 2017.
- [8] F. Milano, *Methodological and Didactic Challenges of Teaching Electrical Energy Systems to Second Year Students*, EDULEARN 2017, Barcelona, Spain, 3-5 July 2017.
- [9] O. I. Elgerd, *Electric Energy Systems Theory: An Introduction*, McGraw-Hill, 1983.
- [10] F. Milano, *Power System Modelling and Scripting*. Springer-Verlag, 2010.
- [11] 32 metronome synchronization, available <https://www.youtube.com/watch?v=5v5eBf2KwF8>
- [12] V. A. Venikov, *Theory of Similarity and Simulation – with applications to problems in electrical power engineering*, Macdonald Technical & Scientific, 1969.
- [13] F. Milano, F. Dörfler, G. Hug, D. J. Hill, G. Verbič, *Foundations and Challenges of Low-Inertia Systems*, 20th Power System Computation Conference (PSCC), Dublin, Ireland, 11-15 June 2018.